



SPARE PARTS MANUAL

Kensington-S

FR510-DXs2b



U.K. 510DXs2b-NB2GBA2

INDEX

P1 HANDLE BAR ASSEMBLY

P2 CHASSIS MOULDINGS

P3 FRONT CHASSIS ASSEMBLY

P4 STEERING SYSTEM

P5 REAR CHASSIS DRIVE SYSTEM

ASSEMBLY

P6 HAND BRAKE ASSEMBLY

P7 SEAT ASSEMBLY

P8 CONSOLE AND WIRING SYSTEM

HANDLE BAR ASSEMBLY

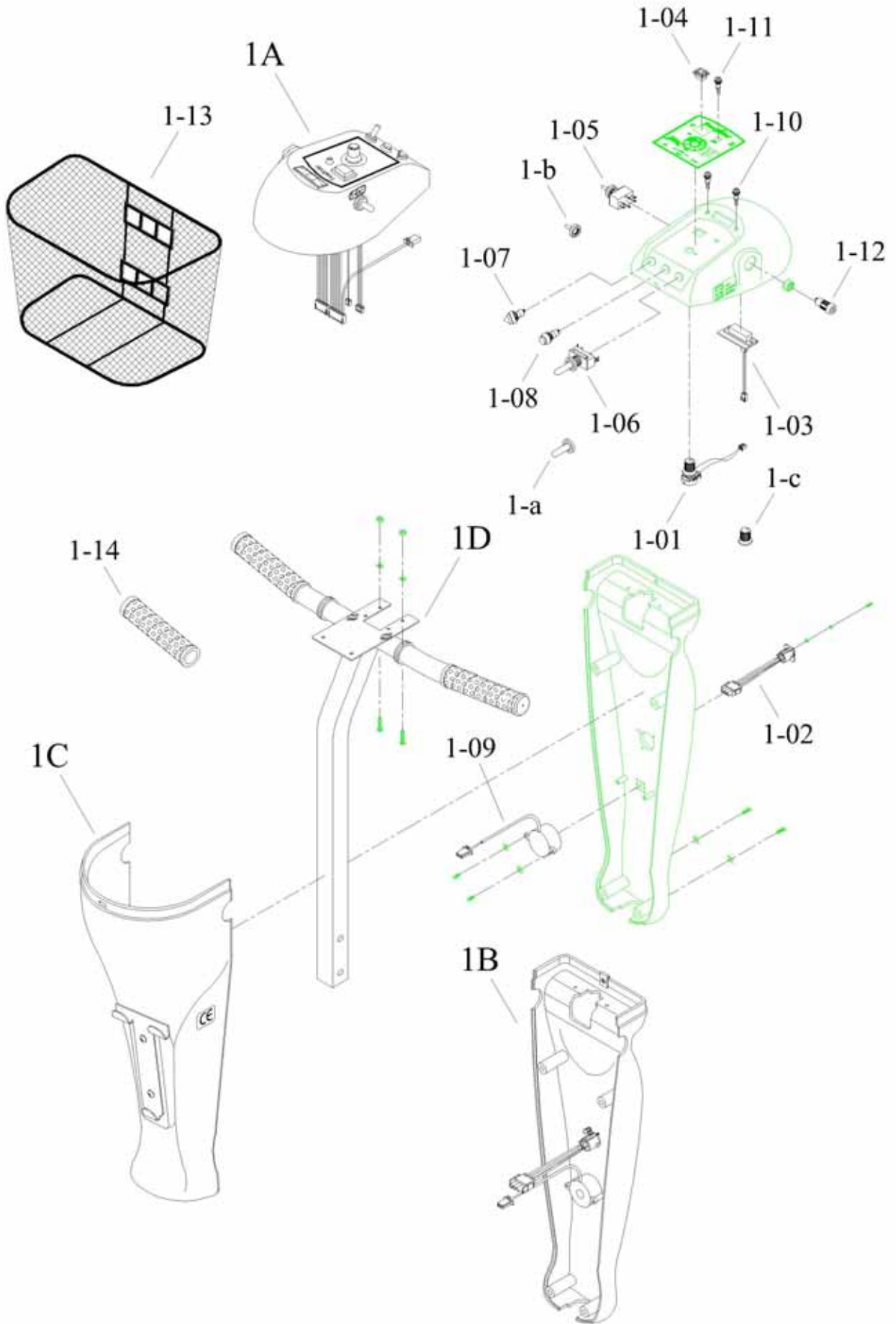

HANDLE BAR ASSEMBLY

DRAWING NO.	PART NO.	PART NAME			
1A	AA01-0300-B2	TOP CONSOLE COVER ASSY.			
1B	AA02-0200-B2	HANDLE BAR COVER REAR ASSY.			
1C	AA03-0200-B2	HANDLE BAR COVER FRONT ASSY.			
1D	PA01-A300	HANDLE BAR ASSY.			
1-01	PAE1-0101-MO	VARIABLE RESISTOR 50KVR ASSY.			
1-02	PAE1-0404-NP	CHARGER SOCKET ASSY.			
1-03	PAE1-0502	BATTERY METER ASSY.			
1-04	PAE1-0800	HEADLIGHT SWITCH ASSY.			
1-05	PKE1-0104	HI/LO SPEED SWITCH ASSY			
1-06	PKE1-0105	INDICATOR SWITCH ASSY.			
1-07	PKE1-0101	WARNING SWITCH			
1-08	PKE1-0103	HORN BUTTON			
1-09	PKE1-0603	HORN			
1-10	PKE1-0800	INDICATOR LED (GREEN)			
1-11	PKE1-0802	HI/LO SPEED LED (RED)			
1-12	PM01-0100	KEY SWITCH			
1-13	PM90-0100	BASKET			
1-14	PP02-0200-PVC	HAND GRIP (NEW)			
1-a	PP01-0200	INDICATOR SWITCH CAP			
1-b	PP01-0201	INDICATOR SWITCH CAP			
1-c	PP01-0500	SPEED KNOB			

CHASSIS MOULDINGS

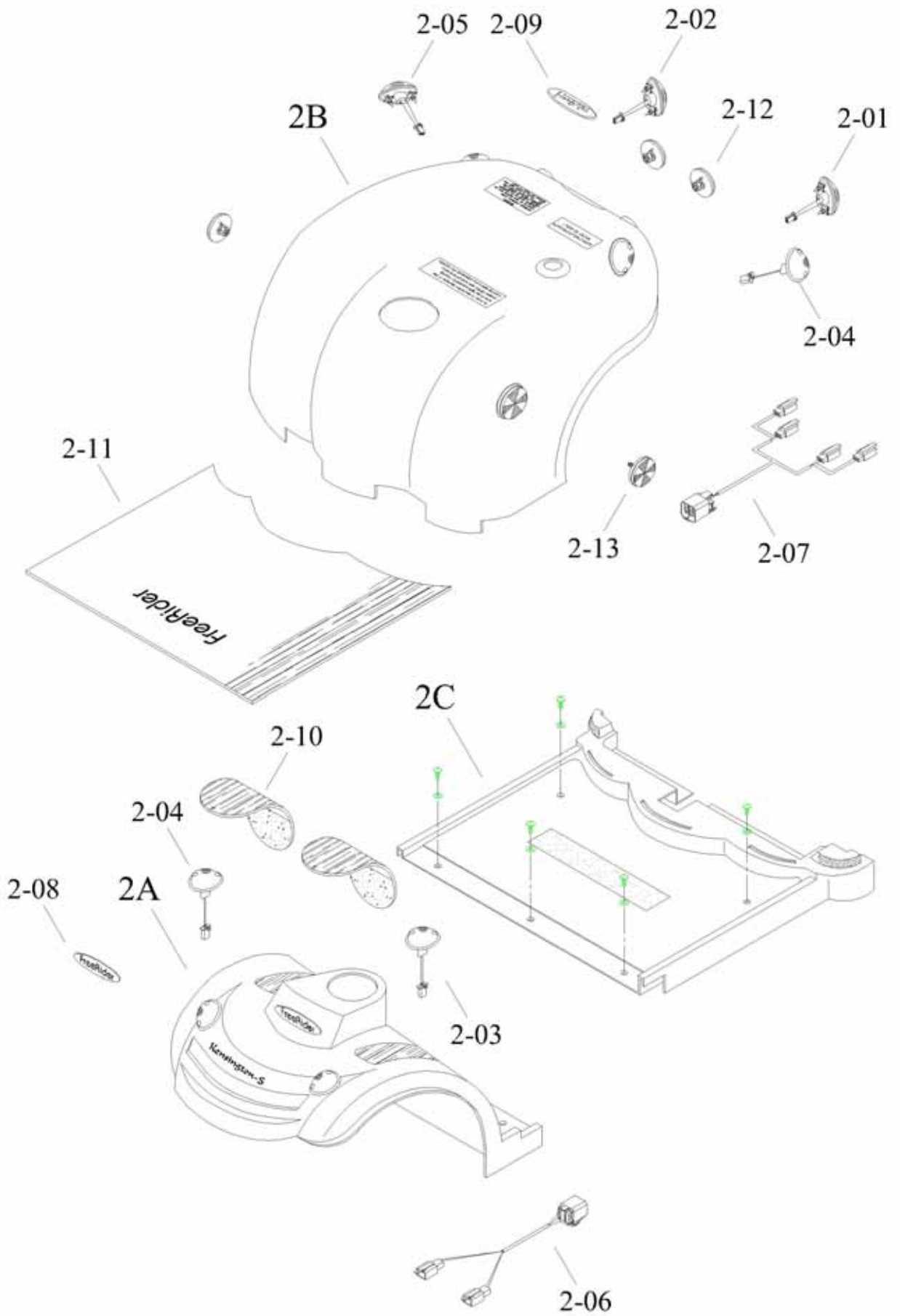

CHASSIS MOULDINGS

DRAWING NO.	PART NO.	PART NAME			
2A	AA04-0900-B2	FRONT CHASSIS COVER ASSY.			
2B	AA05-0800-B2	REAR CHASSIS COVER ASSY.			
2C	AA06-0200-D1	CHASSIS STAMP COVER ASSY.			
2-01	PAE3-0101-L	TAIL LIGHT LEFT ASSY. (RED)			
2-02	PAE3-0101-R	TAIL LIGHT RIGHT ASSY. (RED)			
2-03	PAE3-0201-L	INDICATOR LIGHT LEFT ASSY.			
2-04	PAE3-0201-L/R	INDICATOR RIGHT (R) / LEFT (F) ASSY.			
2-05	PAE3-0201-R	INDICATOR RIGHT ASSY.			
2-06	PKE3-0401	FRONT INDICATOR CONNECTING WIRE			
2-07	PKE3-0501-2	REAR INDICATOR CONNECTING WIRE			
2-08	PL00-0100	DECAL "FREERIDER"			
2-09	PL00-0200	DECAL "FREERIDER"			
2-10	PP04-0404	CARPET			
2-11	PP04-0508	FLOOR MAT			
2-12	PP05-0400-R	REFLECTOR (RED)			
2-13	PP05-0400-Y	REFLECTOR (YELLOW)			

FRONT CHASSIS ASSEMBLY

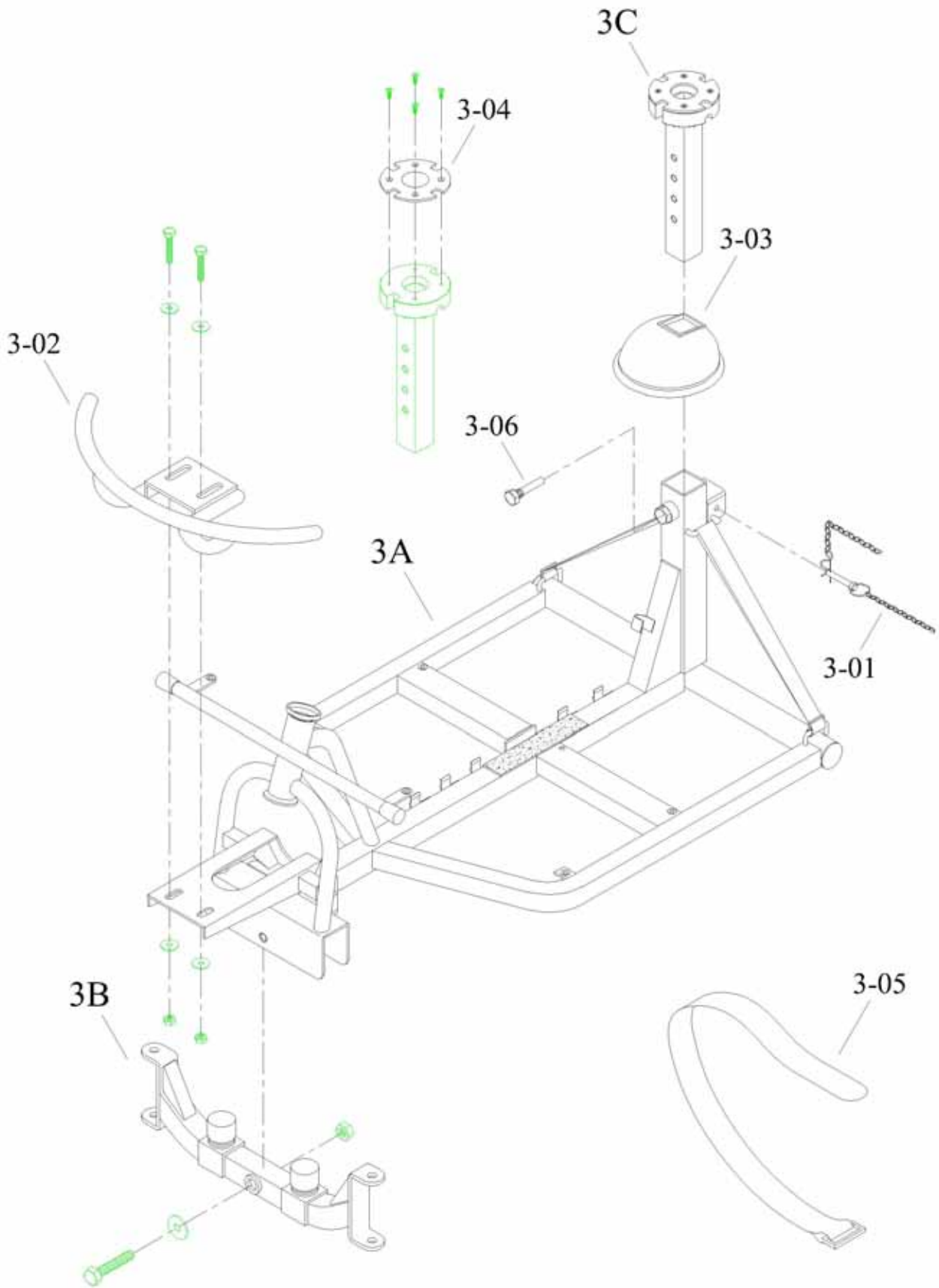

STEERING

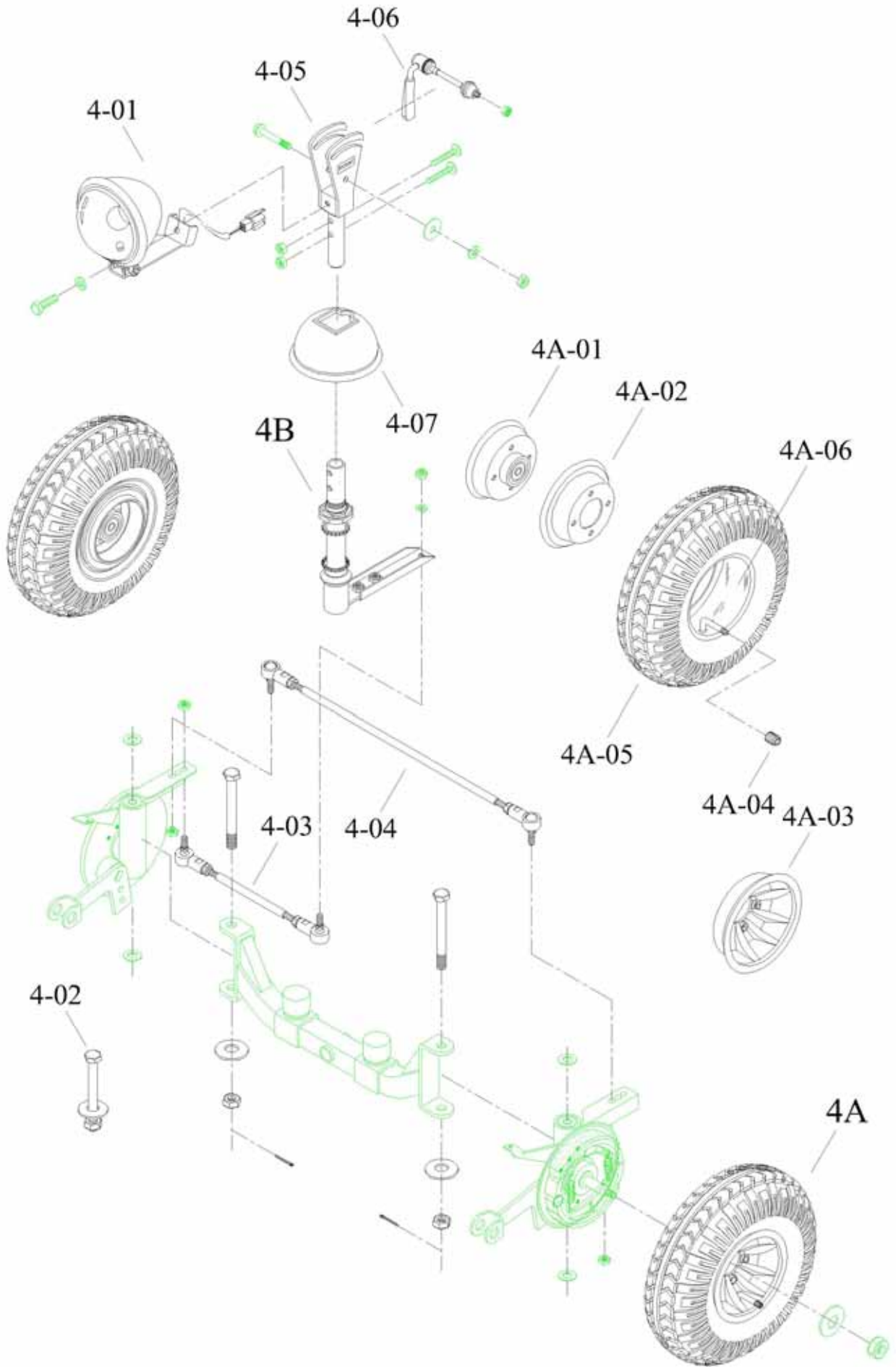

STEERING

DRAWING NO.	PART NO.	PART NAME			
4A	AC12-0800-GI	FRONT WHEEL ASSY.			
4A-01	PA19-A500	BRAKE DRUM ASSY			
4A-02	PM12-0300	INNER RIM (STEEL) 13"			
4A-03	PM12-0400	OUTER RIM (AL., BLACK) 13"			
4A-04	PP92-0001	VALVE CAP			
4A-05	PP92-0400-GI	(400-5) TYRE			
4A-06	PP93-0400-I	(400-5) TUBE			
4B	AC08-0101	STEERING SHAFT ASSY.			
4-01	PA06-A300	ROUND HEAD LIGHT ASSY.			
4-02	PA06-B300	M12×P1.75×117L BOLT ASSY.			
4-03	PA09-A201-H	CONNECTING ROD SHORT ASSY.			
4-04	PA09-A203-H	CONNECTING ROD LONG ASSY.			
4-05	PA10-A100	HANDLE BAR JOINTBASE ASSY.			
4-06	PA10-A200	TIGHTEN HANDLE ASSY.			
4-07	PP10-0101	RUBBER COVER FRONT			

REAR CHASSIS ASSEMBLY-DRIVE SYSTEM

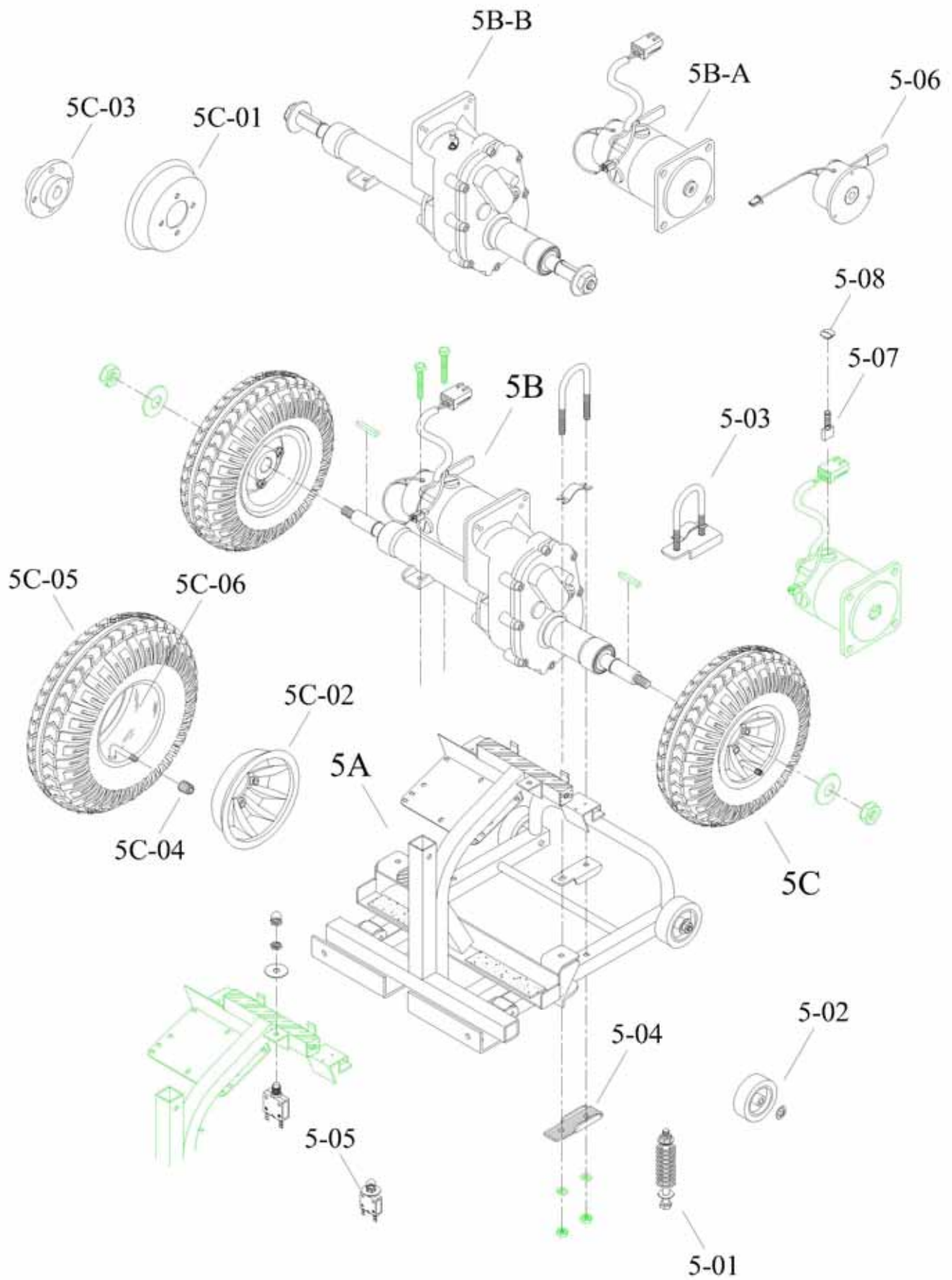

HAND BRAKE ASSEMBLY

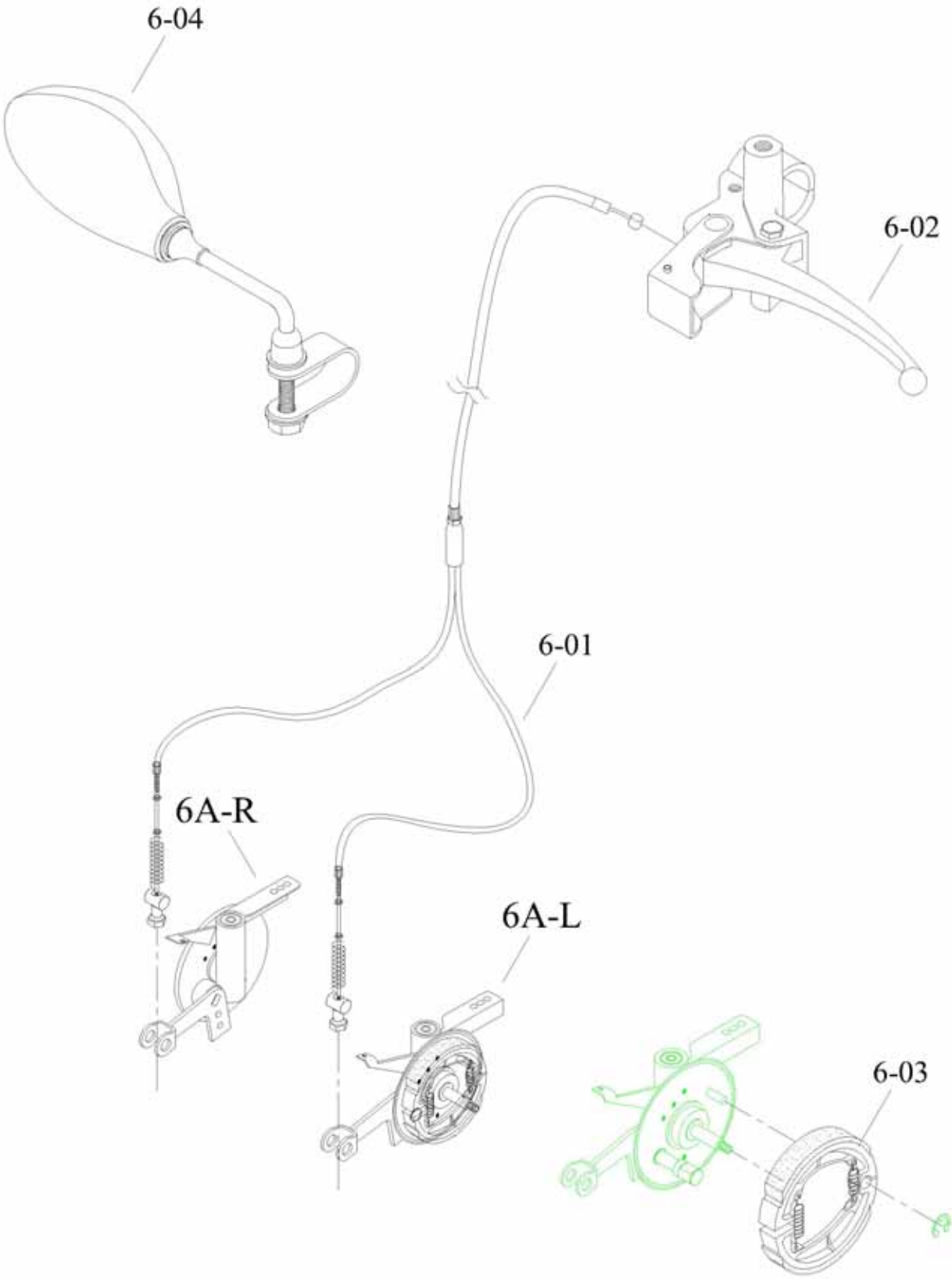

SEAT ASSEMBLY

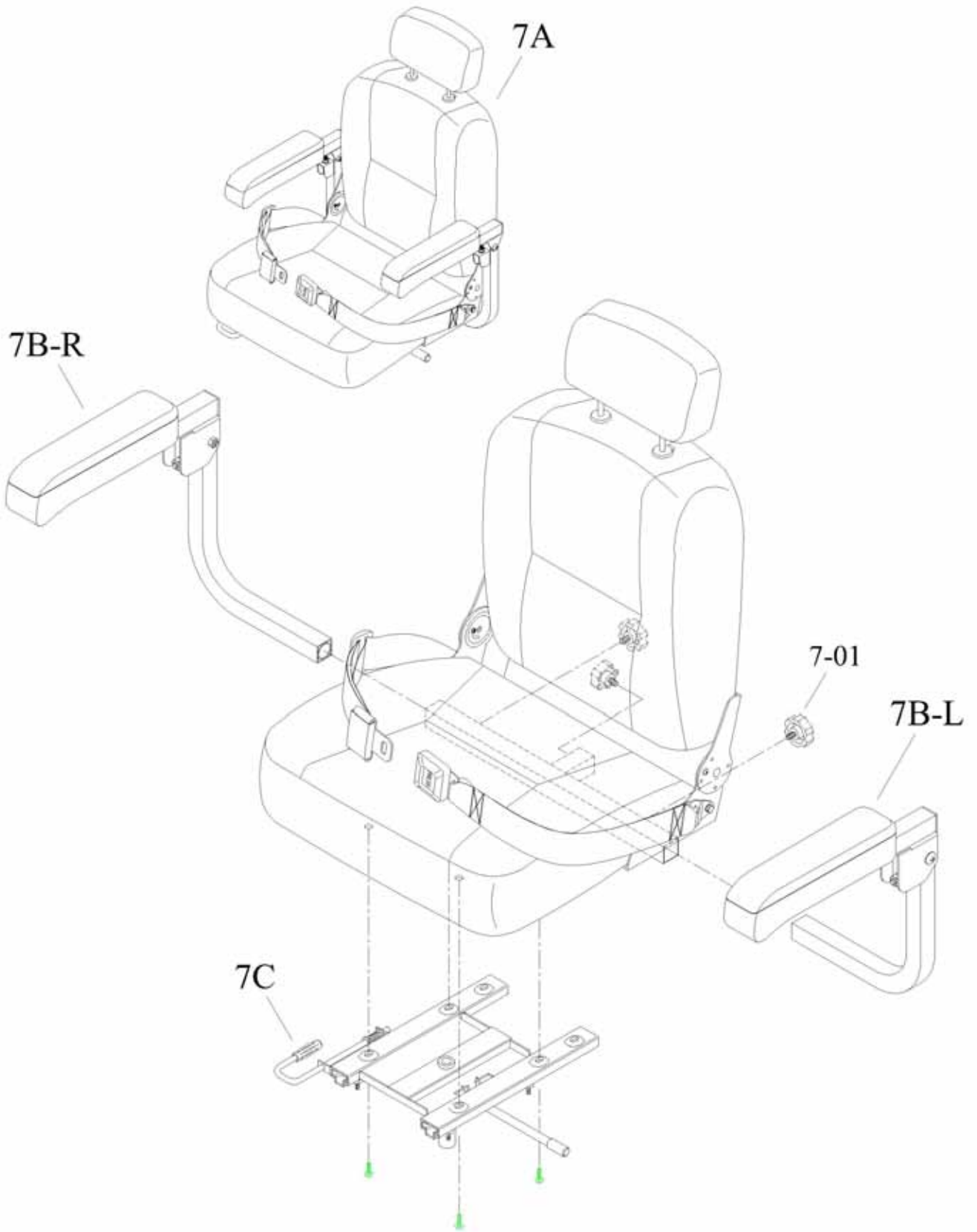

CONSOLE AND WIRING SYSTEM

